

**LANIER**

Making your documents our business

MP C2000/MP C2500  
MP C3000



*Black and White  
& Colour Processors*

COLOUR MFD



# MP C2000/MP C2500/MP C3000

## Create Stunningly Finished B/W and Colour Output

*Your company's first impression is crucial, therefore colour is the tool to show that you mean business. Add it to your business documents and enjoy the benefits right away! Colour increases involvement, engages the interest and persuades faster: ideal for proposals, forms and invoices. Designed to put you in the lead, Lanier's MP C2000/MP C2500/MP C3000 offer a wealth of possibilities that support your creativity and productivity. To revolutionise your business image, you can now provide clients with spectacularly finished documents in black and white and colour. Everything you need to achieve high impact results and the business success that goes with it!*

- All-in-one: print, copy, scan and fax from one device
- High quality B/W and colour output at 20/25/30 ppm
- Easy access & intuitive operation via amazing colour LCD panel
- Advanced faxing and information distribution capabilities
- Exceptional document handling and in house finishing



# Satisfying All Modern Office Communication Needs

Meet the challenges you face with a smart and powerful partner by your side. The Lanier™MP C2000/MP C2500/MP C3000 unite the ease of use and productivity of a black and white device with outstanding colour capabilities. Keep pace with today's growing demands and only go for the best in office communication.

## Impress in Colour

Boost your business image with high impact colour documents. Colour makes a lasting impression! On top of that, your documents become more attractive and readable. The Lanier™MP C2000/MP C2500/MP C3000 make sure you obtain expert results with impeccable detail and sharp images. For special applications requiring thick paper such as menu cards and cover pages, paper of up to 256 g/m<sup>2</sup> can be handled via the bypass tray.



## Continuous Operation

With a maximum paper capacity of 3,100 sheets, replenishments are down to an absolute minimum. The system even switches to the next tray with the same paper when the one in use runs out. You can continue your work without interruptions.

500 sheets

500 sheets

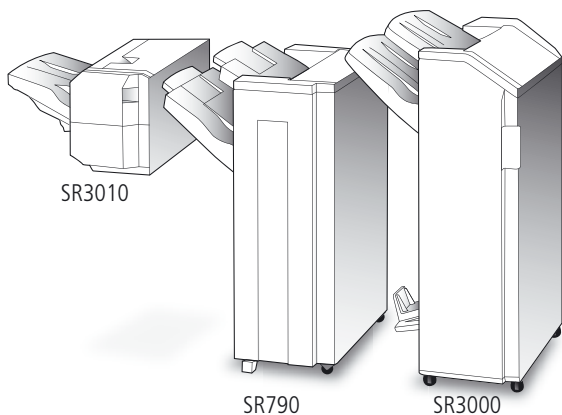

## Finishing Experts

Why resort to expensive outsourcing when you can create professionally finished documents in house? The Lanier™MP C2000/MP C2500/MP C3000 offer an entire range of possibilities to meet your needs: staple, punch and collate with the 500-sheet and 1,000-sheet finisher or create attractive sales, training and presentation material with the systems' booklet finisher.

## Optimal Document Management

For streamlined document handling, all your print, copy, fax and scan data can be stored and managed. Using Web Image Monitor you can retrieve stored data, view files and re-organise, change or delete them through a web browser anywhere, anytime.



## Make your Complex Tasks Easy

Designed to simplify your daily workflow, the Lanier™ MP C2000/MP C2500/MP C3000 allow you to create first class documents with the greatest ease. No technical expertise required!

The advanced colour LCD touch panel offers you:

- the possibility to show only your most frequently used functions
- a preview functionality for optimum usability and improved accuracy
- a crystal clear screen that displays text and images as sharp as on your PC screen
- animated user guidance in case of irregularities

## Intelligent Faxing

With a wealth of smart capabilities at your disposal, you can turn your fax communications into a very smooth running and efficient workflow:

- automatically distribute incoming faxes to e-mail or folder
- forward faxes to a single person or an entire workgroup for optimum efficiency
- reduce costs and optimise efficiency by using the Internet for long distance faxing

Inbound fax messages automatically go to the right person while you omit the distribution of printed faxes and save costs!

500 sheets

500 sheets



## Our Earth, Our Tomorrow

Like all Lanier products, the MP C2000/MP C2500/MP C3000 reflect Lanier's commitment to the environment with the usage of toxic free materials\*, limited ozone & noise emission and low energy toner production.

\* In compliance with EU RoHS directive (RoHS: Restriction of Hazardous Substances, effective from July 2006).



# Power up your Office with the Latest Technologies

*To go that extra mile you need smart solutions that efficiently handle your every day tasks. With the Lanier™ MP C2000/MP C2500/MP C3000, you can get the job done on time, any time. Increase your productivity, easily share information and optimise security. Should your business needs change, your multifunctional device simply grows with you.*

## Top Multifunctional Performers

Whether you are looking for a digital copy/print/scan solution or a full blown multitasker with fax and finishing capabilities, the Lanier™ MP C2000/MP C2500/MP C3000 can be customised to suit your specific needs. In fact, you can process all your documents using one compact multifunctional device: cost efficient and space saving! The system warms up in a mere 45 seconds and your first black and white job is ready in 6.7 seconds\*. Colour prints and copies are on your desk just as fast as black and white documents: at 30 pages per minute for the MP C3000 (25 ppm for the Lanier™ MP C2500, and 20 ppm for the Lanier™ MP C2000) your productivity is never compromised!

\* Full colour: 9.7 seconds

## Efficient Distribution

Digitally organise, edit and distribute information to save time and costs. Instead of filling archive cabinets, you can easily:

- digitise documents and store them on the document server
- share a document by scanning it to the addressee's e-mail address or a specific folder
- avoid network overloads and prevent huge e-mail inboxes by sending an e-mail containing a URL address

## Advanced Printing

The confidential documents you print should stay confidential. With the Lanier™ MP C2000/MP C2500/MP C3000 they remain that way: the system keeps your document until you release it with your password. Print jobs you send during the day can also be held in the digital paper tray. You simply release them at a convenient time. When printing multiple sets, you can avoid misprints by first printing a sample set and correcting it if necessary before the device processes the remaining sets. Should you choose the systems' Adobe® PostScript® 3™ option, you obtain PDF Direct Print, a handy tool to reduce network traffic and increase total productivity.

## Safeguard Access & Information

Protect your business against possible security threats with the latest in authentication, temporary data overwriting and unauthorised copy prevention:

- advanced access limitation: Windows® authentication & colour usage restriction
- prevention of industrial spying & information leaks: Data Overwrite Security Unit
- watermark protection to rule out unauthorised copying



Distributing scanned documents is easy: you can store them on the device's Document Server, send them to any e-mail address in the world or directly to a specific folder in the network.



# MP C2000/MP C2500/MP C3000

DIGITAL COLOUR COPIER/PRINTER/SCANNER/FAX SYSTEM

## COPIER

Copying process:	Laser beam scanning & electro photographic printing	
Copy speed:	MP C2000:	20 copies per minute <sup>1</sup>
	B/W / full colour:	
	MP C2500:	25 copies per minute <sup>1</sup>
B/W / full colour:		
	MP C3000:	30 copies per minute <sup>1</sup>
B/W / full colour:		
Resolution:	600 dpi	
Multiple copy:	Up to 999	
Warm up time:	Less than 45 seconds	
First output speed:	Black and white:	6.7 seconds
	Full colour:	9.7 seconds
Zoom:	25 - 400% (in 1% steps)	
Memory:	Standard:	1,024 MB + 40 GB Hard Disk Drive
Paper input capacity:	Standard:	2 x 500-sheet paper trays 1 x 100-sheet bypass tray
	Maximum:	3,100 sheets
Paper output capacity:	Maximum:	1,500 sheets
Paper size:	A6 - A3 (A3+ via bypass tray)	
Paper weight:	Paper trays:	60 - 216 g/m <sup>2</sup>
	Bypass tray:	60 - 256 g/m <sup>2</sup>
	Duplex tray:	64 - 169 g/m <sup>2</sup>
Dimensions (W x D x H):	650 x 659 x 740 mm	
Weight:	Less than 120 kg (with ARDF)	
Power source:	220 - 240 V, 50/60 Hz	
Power consumption:	Operation:	Maximum 1.5 kW
	Energy saver mode:	99 W

## PRINTER

Print speed:	MP C2000:	20 prints per minute
	B/W / full colour:	
	MP C2500:	25 prints per minute
B/W / full colour:		
	MP C3000:	30 prints per minute
B/W / full colour:		
Printer language:	Standard:	PCL5c, PCL6, RPCS™
	Option:	Adobe® PostScript® 3™
Resolution:	600 x 600 dpi/2,400 x 600 dpi (equivalent)	
Interface:	Standard:	USB 2.0 Ethernet 10 base-T/100 base-TX
	Option:	Bi-directional IEEE 1284 FireWire (IEEE 1394) Wireless LAN (IEEE 802.11b) Bluetooth USB Host I/F
Network protocol:	TCP/IP, IPX/SPX, AppleTalk	
Supported environments:	Windows® 95/98/Me/NT4.0/2000/XP/Server 2003	
	Novell NetWare 3.12/3.2/4.1/4.11/5.0/5.1/6/6.5	
	UNIX: Sun® Solaris 2.6/7/8/9/10 HP-UX 10.x/11.x/11iv/11i	
	SCO OpenServer 5.0.6/5.0.7 RedHat® Linux 6.x/7.x/8.x/9.x/Enterprise IBM® AIX v4.3/5L v5.1/5L v5.2/5.3	

Macintosh 8.6 or later (OS X Classic)  
Macintosh X v10.1 or later (native mode)  
IBM® System i5™ HPT  
SAP® R/3®  
NDPS Gateway  
AS/400® using OS/400 Host Print Transform

## SCANNER

Scan speed:	Maximum 50 originals per minute (MH, A4)
Resolution:	Maximum 1,200 dpi (1,200 dpi TWAIN black and white, greyscale)
Original size:	A5 - A3
Output formats:	PDF/JPEG/TIFF/High compression PDF
Bundled drivers:	Network, TWAIN
Scan to e-mail:	SMTP (optionally with POP authentication)
Destination addresses:	Maximum 500 per job
Stored destination addresses:	Maximum 2,000
Address book:	Via LDAP or locally on Hard Disk Drive
Scan to folder:	SMB, FTP or NCP
Destination:	Maximum 50 folders per job

## SOFTWARE

- SmartDeviceMonitor™
- Web SmartDeviceMonitor™
- Web Image Monitor
- DeskTopBinder™ Lite

## FAX (option)

Circuit:	PSTN, PBX	
Compatibility:	ITU-T (CCITT) G3	
	ITU-T (T.37) Internet fax	
	ITU-T (T.38) IP fax	
Modem speed:	Maximum 33.6 Kbps	
Resolution:	Standard/detail:	200 x 100/200 dpi
	Maximum:	400 x 400 dpi (option)
Compression method:	MH, MR, MMR, JBIG	
Scanning speed:	0.40 seconds (A4 / LEF)	
Memory capacity:	Standard:	4 MB
	Maximum:	28 MB
Memory backup:	Yes	

## OTHER OPTIONS

Platen cover, 2 x 500-sheet paper trays, 2,000-sheet large capacity tray, 500-sheet finisher, 1,000-sheet multi-tray finisher, 1,000-sheet booklet finisher, Punch kits, Shift sort tray, One bin tray, Bridge unit, Adobe® PostScript® 3™, Bi-directional IEEE 1284, FireWire (IEEE 1394), Wireless LAN (IEEE 802.11b), Bluetooth, USB Host I/F, Camera Direct Print card, 2nd G3 port, SAF memory, Data Overwrite Security Unit, Copy Data Security Unit, Professional software solutions

1Simplex.

For availability of models, optional apparatus and software, please contact your local Lanier representative.



LANIER(AUSTRALIA)PTY.LTD.  
A.B.N. 39 001 568 958  
www.lanier.com.au

**a1 Copiers**  
1300 212 674



**AUTHORISED DEALER**